

DGT Projects B.V.
P.O. Box 1295
NL 7500 BG Enschede
Tel. +31-(0)53-
4305195
Fax +31-(0)53-

DGT projects

Multiple DGT Electronic Boards In a Tournament Situation

Author: Ben Bulsink
Date: October 4th, 1998
Correction: August 16rd, 2000
© Copyright 1998, 1999, 2000 DGT Projects

Chapter 1	Overview
Chapter 2	Network structure and limits
Chapter 3	Description of the materials
Chapter 4	Practical situations
Chapter 5	Problems and solutions with the connection network
Chapter 6	Problems and solutions with the boards

Chapter 1 Overview

The DGT Electronic Chess board has special communication features to ease the use of the board at tournaments. The boards can be connected in a network which has the following advantages:

- Easy to install
- Flexible cable routing
- High degree of data integrity
- Simple adaptation or replacement of cable segments and connection points
- Minimal cabling overhead
- Sufficient scanning and processing speed for all chess applications

A typical networking for a tournament would have the following structure: The chess boards are divided into groups, where each group can be placed in a relatively small area. The number of boards in a group has a maximum of 48. Every group of boards is controlled by one data processing computer. These computers, on their turn, are connected by a local area network. On this local area network, one or more powerful computers are added that have the function of ordering the retrieved game data, restructure them, and further processing for broadcasting or archiving.

This document describes the networking from the chess boards up to the serial port of the data processing computer. The description of software, computers and LAN should be obtained by the developers of the used tournament software. In this document the usage of the tournament software from Tasc B.V., Rotterdam, The Netherlands is assumed.

Chapter 2 Network structure and limits

The networking structure is optimized for normal tournament situations. The network topology is described below, starting from the highest level of data gathering, down to the separate chess boards and clocks.

At least one computer must be available to function as network server. On this computer (hereafter referred to as the supervisor computer), the game data are retrieved from a Local Area Network (LAN), that connects all playing rooms. In every playing room (or in a separate room close to the playing room) a data processing computer (hereafter referred to as the XB computer) is placed, which has a connection to the above mentioned LAN.

This XB computer has direct connection to a group of chess boards.

This document describes the networking of the boards and their connection to the XB computer.

Group size

Basically the chess boards are connected to serial ports of the XB computer. On every single serial port of this computer up to 12 chess boards can be connected. The amount of chess boards that can be controlled by the XB computer depends on some aspects:

1. The amount of serial ports on the XB computer. As said up to 12 boards can be connected to one serial port.
2. The execution speed of the XB computer. For the moment, using a 200 MHz Pentium PC up to 48 boards can be processed while communicating every second with every board. Provided higher speed computers, more serial ports could be installed in the PC for controlling more buses of 12 boards.
3. The damage occurred at a breakdown of an XB computer. The more boards are controlled by one computer, the more damage in the tournament registration occurs at a breakdown of this computer.
4. The area over which the chess boards are spread out: The total length of cable used to connect a board to the XB computer may not exceed 50 meters. See also the next paragraph.

This XB computer should be placed relatively close to the group of chess boards, and of course must be attached to the LAN. A separation between the playing area and the place of the computer is recommended, so that eventually operation actions at the XB computer does not disturb the players.

Bus

Every serial port of the XB computer a so called *bus* of boards. The bus is basically a two-directional data transport structure with power lines for the boards. The boards of the bus (up to 12) are attached on this bus. A separate unit, placed at the XB computer table, provides power for the chess boards. This power is distributed to the boards using the same bus structure.

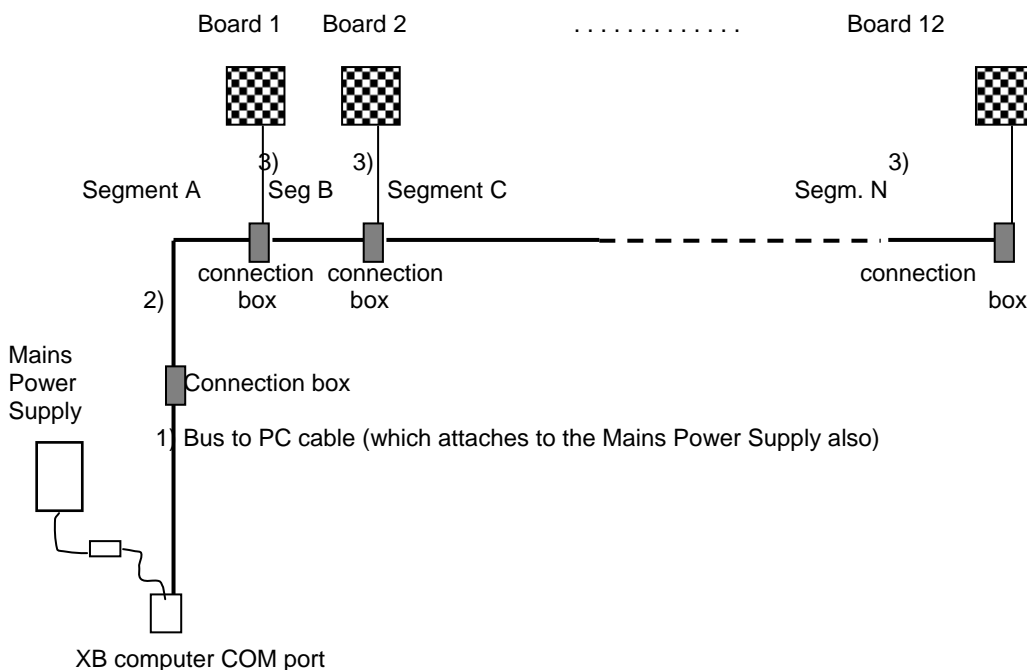

Drawing 1: Single branch

The bus is powered by 100-240 Volt 50/60 Hz AC mains power adapter. DC power is distributed by means of a stabilizing 11.5V DC (1000 mA) mains adapter. The bus is connected to a PC COM port by means of a bus-to-PC cable 1). Also the mains adapter is connected to this cable.

(NOTE: this is an improvement of the older system with the bus power box. The two powering systems are not compatible: the two types adapters can not be interchanged. The busses starting with segment A are however compatible and interchangeable).

The bus-to-PC cable connects to the bus by means of a connection box. From this connection box, a segment cable 2) leads to the first board connection box. This is basically a splitting point in the bus structure and provides for a connector to attach a board to the bus. At this connection box, a board-to-bus cable (marked "3" in the drawing) connects the board to the bus, and the connection box leaves a socket for the second segment cable (marked Seg B in the drawing). This second segment cable leads to a new connection box, where a second board is connected to the bus (The board-to-bus cable provides for attaching a DGT TopMatch Chess Clock, to be placed next to the chess board). Up to 12 boards can be connected to the bus, by using 12 connection boxes, 12 board-to-bus cables and 12 segment cables

The connection box can also be used to split the bus. This is done by connecting a segment cable at the position where the board-to-bus cable would be connected. (see drawing 2)

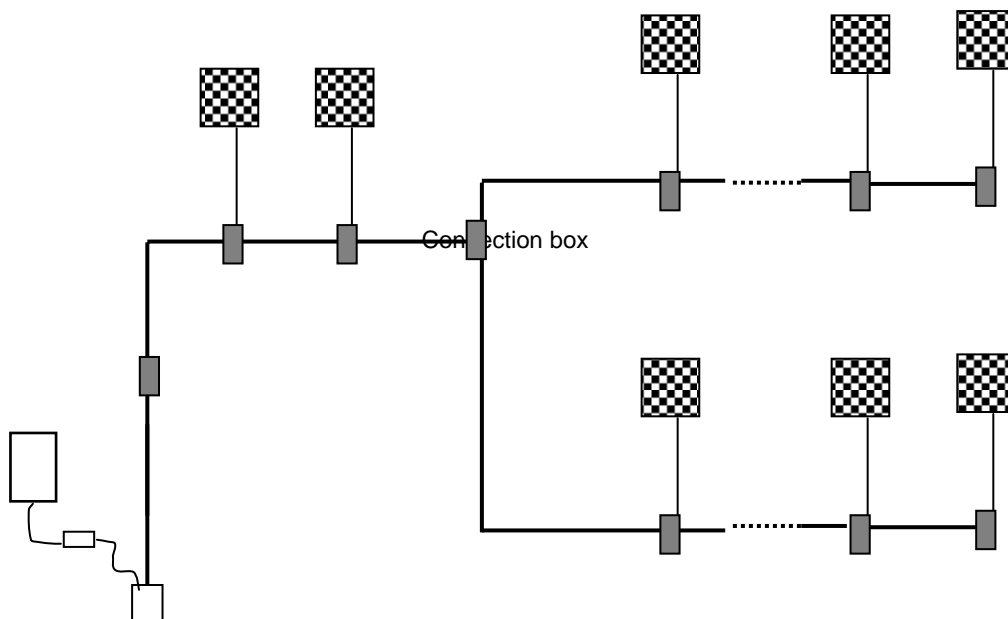

Drawing 2: Multiple branches

This bus splitting can be repeated on the new secondary branches. Note however, that the number of connection boxes between any board and the branch power unit may not exceed 15.

Limits

The total length of segment cable between any board and the bus power unit may not exceed 50 meters. The total length of segment cable attached to one bus power unit, being part of the same branch may not exceed 75 meters. The length of the board-to-bus cable is approx. 60 cm.

Chapter 3 Description of materials

The following components are needed for installing a network of DGT chess boards:

1. DGT Electronic Chess Boards. Each board in a tournament must have a different serial number. The manufacturer will take care of this at the production. In case of doubts the serial number can be checked by the board test program QUEEN.

The software version of the attached chess board should be 1.01 or higher. This software version can also be checked with the above mentioned test program.

2. Bus to PC cable. This (approx. 75 cm) cable connects to a 9-pin PC COM-port, and to a regular connection box of the bus. Also a cable to the mains adapter splits off the Bus-to-pc cable.

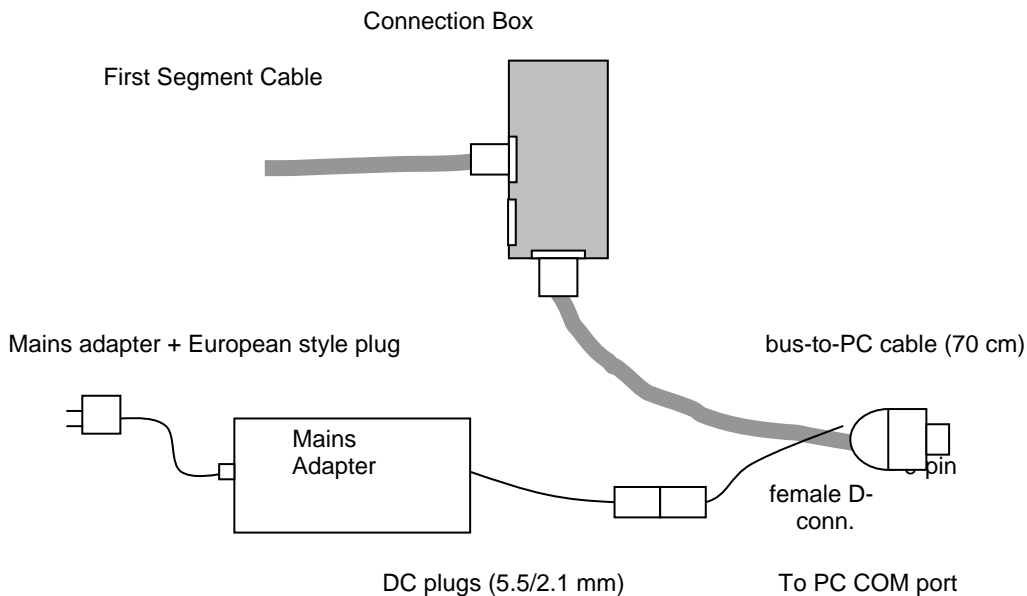

Drawing 3: Branch Power Unit

From all of these parts, one is needed for every branch cq. COM-port.

3. Mains Adapter. Provided is a 100 to 240V AC 50/60 Hz, switching adapter with 11.5 V DC outlet (2.1/5.5 mm DC plug). The adapter is standard delivered with EURO style case connector and a cable to European mains plug.
4. The segment cables are designed for easy reproduction. The cables might be made on specific length for every tournament. A segment cable is made by means of RJ45 Modular Jack connectors and a length of 8 conductor modular cable. For making of the cables, a RJ45 hand tool is needed.
Both ends of the cable should have identical placement of the connector.
No twisting is allowed.

The number of needed segment cables is at least equal with the number of

boards.

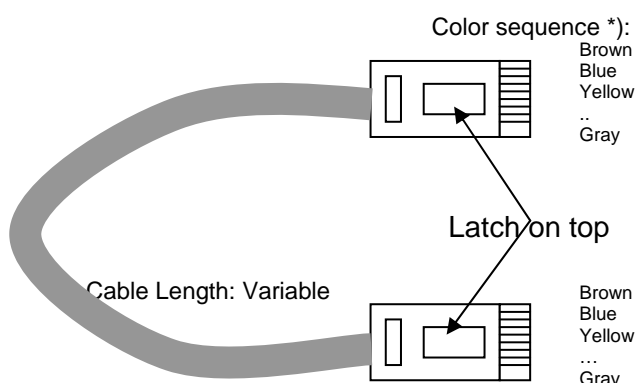

*) Color coding of cable can variate

Drawing 4: Segment Cable

5. Connection Boxes.

For every board and for every dividing of a branch into two sub branches a connection box is needed. A connection box might also be used for joining two segment cables into a longer one. In that case, please note the *limits* paragraph.

(NB: Although the printing on the box suggests a special use of every connector, all three connectors in the box are technically equal and may be swapped)

6. Board-to-bus Cables. Every board must be connected to a connection box, using the Board-to-Bus cable. The length of this cable is approx. 70 cm and the cable provides for attachment of a DGT TopMatch clock.

7. Construction material. The connection boxes and used segment cables should be attached to the floor or the used tables. For this, double and single side adhesive tape or *buddies* can be used. These materials are not included with shipments from DGT Project.

Chapter 4 Practical situations

As a preparation for installing networks of boards, the floor plan with chess tables drawn in should be obtained, i.e. from the arbiter of the tournament. Then a cable plan can be made, taking in account the following aspects:

- Avoid that many people have to cross any cable
- Make groups of tables, that can easily connected with short segment cables
- Avoid that the chess players will be hindered by cables, i.e. at their feet, or in sight
- Try to keep the possibilities to replace segment cables or connection boxes, in case of bad connection or disrupted connectors.
- Place connection boxes in a way that no mechanical stress is applied to the connectors of the cables

- Keep in mind that the XB computer needs a power socket and a connection to the local area network

In practical situations, i.e. when the tournament is spread over smaller rooms on a certain distance, it might be impossible to reach the amount of 48 boards on one type B computer. Be informed in time, to be able to get more PC's.

Chapter 5 Problems and solutions with the connection network

The following errors might occur:

- A segment cable is constructed wrongly: One of the two ends have an opposite color sequence. Also, a bad connection might have occurred at pressing the connectors, or a cable might be corrupted.
- A connector of a segment cable is badly attached: one or more of the conductors make no connection, or a short-circuit occurs. Find the location by attaching the segment cables one by one, until the error is found.
- The connection between a segment cable and a connection box is bad: Due to dirt or oxidation no connection is made on one or more contact points. Plug and unplug several times to remove the dirt
- The adapter does not deliver the right voltage, or the right polarity. The adapter might collapse only with a certain number of boards connected. Replace the adapter.
- The bus-to-PC cable is defected. Replace it.

A general diagnose-and-cure manual is not given. Try to locate the erroneous component, by removing segment after segment, starting at the end of a branch, or by adding segment after segment, starting at the beginning of the bus.

Chapter 6 Problems and solutions with the boards

After installing the network between the boards and the XB computer(s), each XB computer can be started, during which it reports the board numbers that are found on the network. When not all connected boards are reported, the search for the cause can start, for which the notes of chapter 5 can be useful.

It needs also to be inspected whether all boards function properly. The problems that might occur are:

- Bad board-to-bus cable. Check and replace
- The board electronics does not communicate anymore. The board should be replaced

The final check is on the sensory process: put the chess sets in a starting position and check the report of the XB computer. Sometimes one pawn might not be seen: Swap some pawns in the row of black or white.

In the practical situation, it occurs quite often that in the starting position the kings and queens are swapped, or knights and bishops. Pay special attention on that.

